

PRODUCT DATA DRAWING

REVISION HISTORY			
REV	DESCRIPTION	DATE	APPROVED
E	DCN 41843	11/15	STW

MATERIAL:

BODY,
FERRULE,
PRESS CAP &
COUPLING NUT:

STAINLESS STEEL PER AMS-5640,

CONTACT:

BRASS PER ASTM B16, ALLOY UNS No. C36000
ALLOY UNS S30300, TYPE 1

CRIMP RING:

COPPER OR BRASS

LOCK RING:

BERYLLIUM COPPER PER ASTM B196,
ALLOY No. UNS C17300, TD04

INSULATOR:

PTFE PER ASTM D1710, TYPE I, GRADE 1, CLASS B

GASKET:

SILICONE RUBBER PER A-A-59588,
CLASS 2B, GRADE 50/60

SHRINK TUBING:

POLYOLEFIN PER M23053/4, CLASS 1

FINISH:

BODY,
FERRULE,
PRESS CAP &
COUPLING NUT:

GOLD PER ASTM B 488, TYPE I,
CODE C, CLASS .50, OVER NICKEL
PER AMS-QQ-N-290, CLASS 1, .00005" MIN.

CONTACT:

GOLD PER ASTM B488, TYPE II,
CODE C, CLASS .76, OVER NICKEL
PER AMS-QQ-N-290, CLASS 1, .00005" MIN.

PERFORMANCE:

IMPEDANCE:
FREQ. RANGE:

50 OHMS
DC TO 12.4 GHz

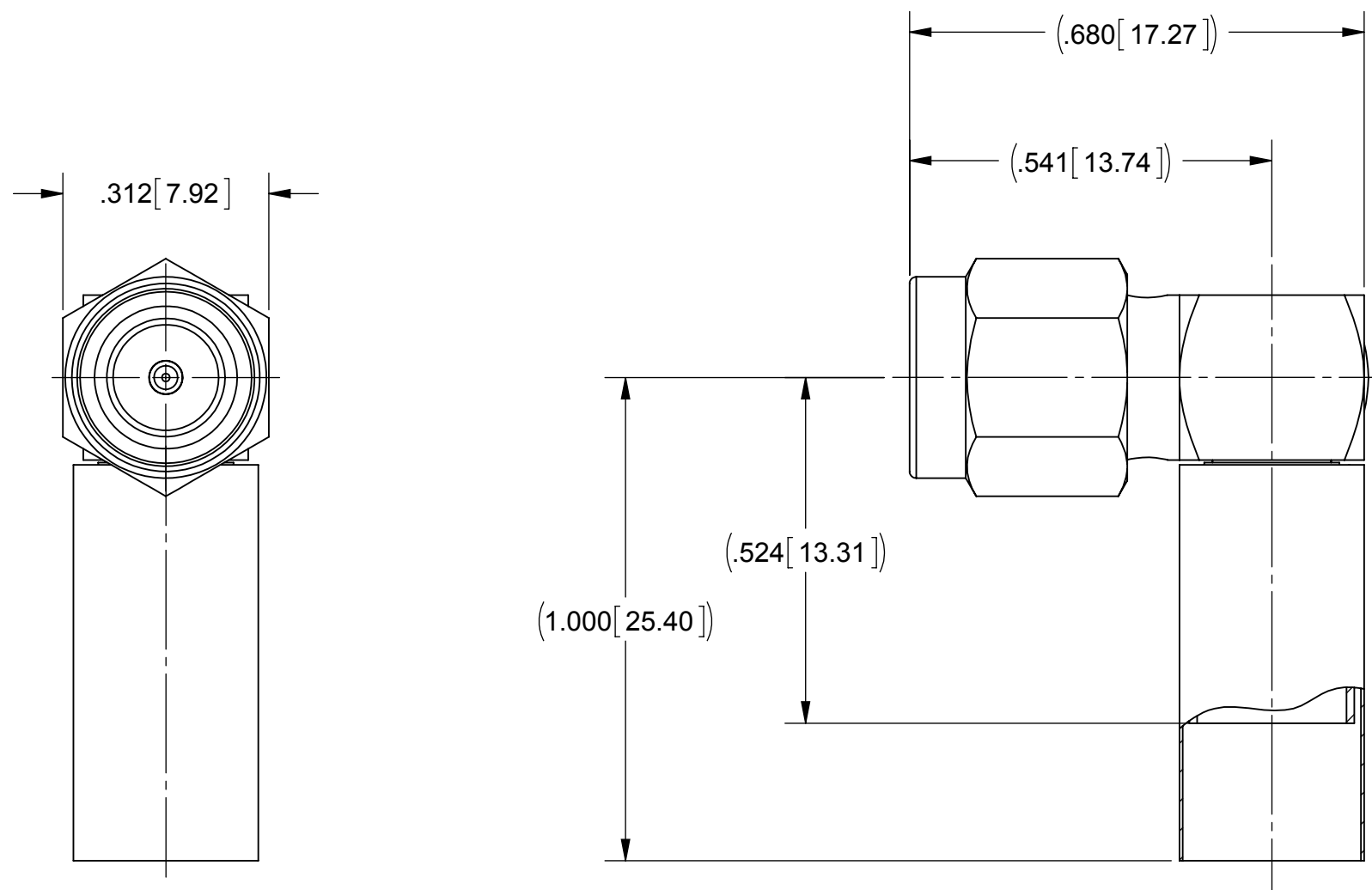

MATERIAL:	SEE NOTES
FINISH:	SEE NOTES
SURFACE AREA:	N/A
PROPRIETARY	
THE INFORMATION CONTAINED IN THIS DRAWING IS THE SOLE PROPERTY OF SV MICROWAVE, INC. ANY REPRODUCTION IN PART OR AS A WHOLE WITHOUT THE WRITTEN PERMISSION OF SV MICROWAVE, INC IS PROHIBITED.	

DIMENSIONS ARE IN INCHES TOLERANCES:	
FRACTIONAL:	±1/64 ANGULAR: X° ±1'0" X*X' ±15'
DECIMAL:	X ±.030 .XX ±.010 .XXX ±.005
INTERPRET DIMENSIONS AND TOLERANCES PER ASME Y14.5M - 1994	
THIRD ANGLE PROJECTION	

UNLESS OTHERWISE SPECIFIED	
1) ALL DIMENSIONS ARE IN INCHES (MILLIMETERS) 2) ALL DIMENSIONS ARE AFTER PLATING. 3) BREAK CORNERS & EDGES .005 R. MAX. 4) CHAM. 1ST & LAST THREADS. 5) SURFACE ROUGHNESS 63-MIL-STD-10. 6) DIA: 'S ON COMMON CENTERS TO BE CONCENTRIC WITHIN .005 T.I.R. 7) REMOVE ALL BURRS	
DRAWN:	BRT 04/14/97
CHECKED:	
APPROVED:	DGG 04/16/76

Amphenol 2400 Centrepark West Drive, Suite 100 West Palm Beach, FL 33409	
TITLE: SMA PLUG R/A CRIMP FOR RG-55, RG-142, 223/U	
SIZE	CAGE CODE DWG. NO.
B	95077 2910-6001
SCALE: 4:1	SHEET 1 OF 1