

THIS IS A C.A.D. GENERATED DRAWING
DO NOT MAKE MANUAL REVISIONS TO MASTER.

* UNLESS OTHERWISE SPECIFIED TOLERANCES
ON DECIMAL IS:
FRACTION $\pm 1/32$
2 PLACE $\pm .01$
3 PLACE $\pm .005$

ISSUE NUMBER
ADD NOTE TIP TO BE HARDENED.
RE-DESIGN DRAWING
R:STAMONICA MAR:14/2014

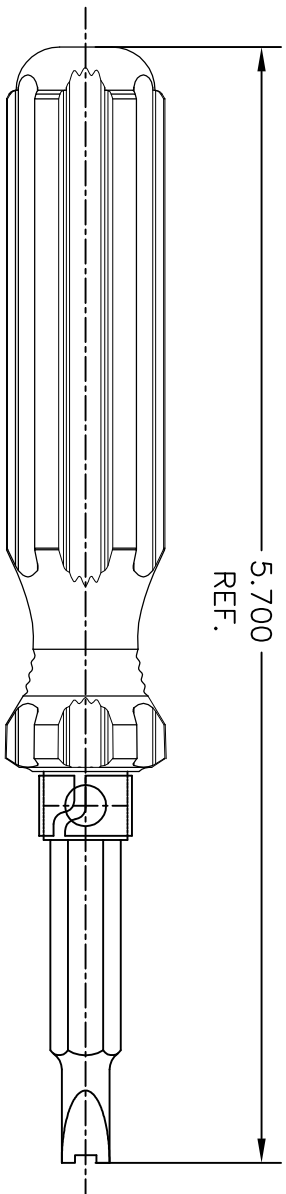

EDAC PART NUMBER (SCREW DRIVER ASSY.) 516-280-500
EDAC PART NUMBER (SCREW DRIVER TIP) 516-280-500-010

NOTE: SCREWDRIVER TIP (516-290-500-010) MUST FIT INTO
HANDLE AND LOCK INTO PLACE WHEN INSERTED IN EITHER
DIRECTION

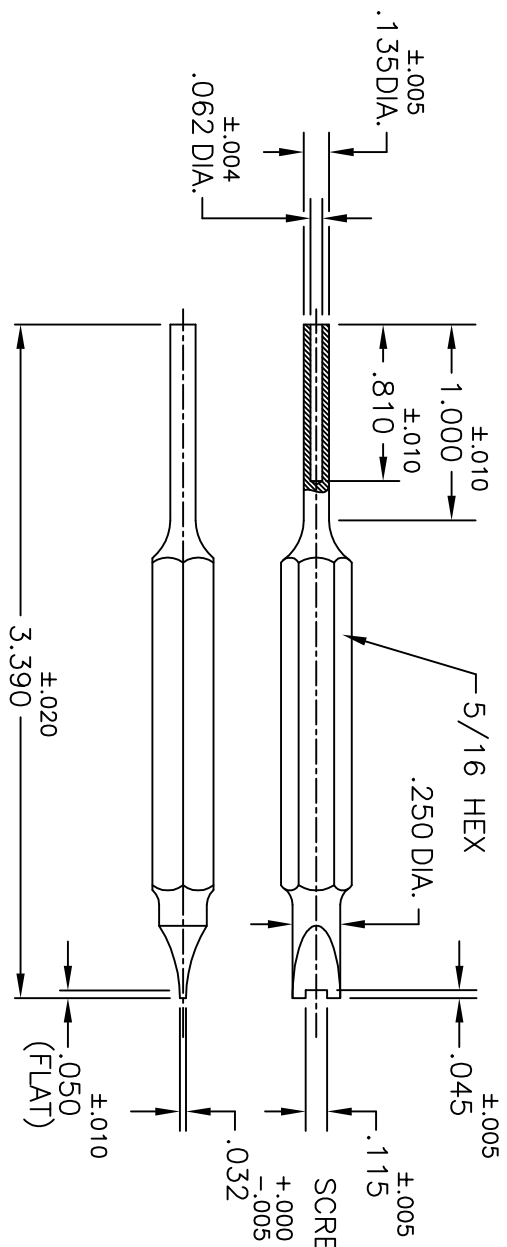

SCREW DRIVER TIP MUST BE HARDEN

516 POLARIZING ROUND NUT DRIVER

ACAD REFERENCE NO. 51628050	
DRAWN: F.BRIONES	DATE: MAR.27/00
CHECKED:	DATE:
SCALE: (IN C.A.D. 1:1)	SHEET 1 OF 1
DRAWING NUMBER 516-280-500	ISSUE 3

EDAC INC
TORONTO, ONTARIO
CANADA
YOUR CONNECTION TO QUALITY & SERVICE

THESE DRAWINGS AND SPECIFICATIONS
ARE THE PROPERTY OF EDAC INC. AND
SHALL NOT BE REPRODUCED, OR COPIED
OR USED AS THE BASIS FOR THE
MANUFACTURE OR SALE OF APPARATUS
WITHOUT WRITTEN PERMISSION.